

INSTALLATION MANUAL

MONTAGEANLEITUNG

INSTRUCTIONS DE MONTAGE

ISTRUZIONI PER IL MONTAGGIO



970.562.00.0(03)

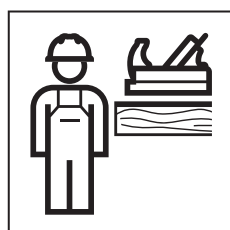
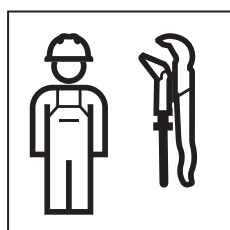



WARNING

Unsachgemäße Montage

Herabfallen des Produkts kann zu schweren Verletzungen führen.

- ▶ Vor der Montage die Tragfähigkeit der Wand prüfen.
- ▶ Vor der Montage prüfen, ob das mitgelieferte Befestigungsmaterial für den Wandtyp geeignet ist. Das Befestigungsmaterial bei Bedarf austauschen.



WARNING

Incorrect installation

If the product falls, it can cause serious injuries.

- ▶ Before installation, check the bearing capacity of the wall.
- ▶ Before installation, check whether the fastening material supplied is suitable for the wall type. Use a different type of fastening material if necessary.



AVERTISSEMENT

Montage inapproprié

La chute du produit peut entraîner des blessures graves.

- ▶ Avant le montage, contrôler la capacité portante de la paroi.
- ▶ Contrôler avant le montage que le matériel de fixation fourni avec la livraison est adapté au type de paroi. Remplacer si nécessaire le matériel de fixation.



AVVERTENZA

Montaggio improprio

La caduta del prodotto può provocare gravi lesioni.

- ▶ Testare la capacità di carico della parete prima del montaggio.
- ▶ Prima del montaggio, controllare che il materiale di fissaggio fornito sia adatto al tipo di parete. Se necessario, cambiare il materiale di fissaggio.



WAARSCHUWING

Ondeskundige montage

Het eraf vallen van het product kan tot ernstig letsel leiden.

- ▶ Vóór de montage het draagvermogen van de wand controleren.
- ▶ Vóór de montage controleren, of het meegeleverde bevestigingsmateriaal voor het wandtype geschikt is. Indien nodig het bevestigingsmateriaal vervangen.



ADVERTENCIA

Montaje inadecuado

La caída del producto puede ocasionar lesiones graves.

- ▶ Antes del montaje, comprobar la capacidad de carga de la pared.
- ▶ Antes del montaje, comprobar si el material de fijación suministrado es el apropiado para el tipo de pared. En caso necesario, cambiar el material de fijación.



AVISO

Montagem incorreta

A queda do produto pode provocar ferimentos graves.

- ▶ Verificar a capacidade de carga da parede antes da montagem.
- ▶ Antes da montagem, verificar se o material de fixação fornecido é adequado para o tipo de parede. Substituir o material de fixação, caso necessário.



ADVARSEL

Uhensigtsmæssig montering

Hvis produktet falder ned, kan det føre til alvorlige kvæstelser.

- ▶ Kontroller væggens bæreevne inden monteringen.
- ▶ Kontroller inden monteringen, om det medfølgende fastgørelsesmateriale er egnet til vægtypen. Udskift fastgørelsesmateriale ved behov.



ADVARSEL

Ufagmessig montering

Hvis produktet faller ned, kan det føre til alvorlige personskader.

- ▶ Kontroller bæreevnen til veggen før monteringen.
- ▶ Kontroller før monteringen om det medfølgende festematerialet egner sig for veggtypen. Byt festemateriale ved behov.



VARNING

Felaktig montering

Om produkten faller ned kan den orsake allvarliga personskador.

- ▶ Kontrollera väggens bärförmåga före monteringen.
- ▶ Kontrollera före monteringen om det medföljande infästningsmaterialet lämpar sig för vaggtypen. Byt ut infästningsmaterialet vid behov.



VAROITUS

Epäasianmukainen asennus

Tuotteen putoaminen voi aiheuttaa vakavia vammoja.

- ▶ Tarkasta ennen asennusta seinän kantavuus.
- ▶ Tarkasta ennen asennusta, soveltuuko mukana toimitettu kiinnitysmateriaali seinätyyppiin. Vaihda kiinnitysmateriaali tarvittaessa.



VIÐVÖRUN

Ekki farið rétt að við uppsetningu

Ef varan fellur niður getur það valdið alvarlegum meiðslum.

- ▶ Kanna skal burðargetu veggs áður en uppsetning fer fram.
- ▶ Ganga skal úr skugga um að meðfylgjandi festibúnaður henti fyrir vegginn áður en uppsetning fer fram. Ef þörf krefur skal nota annan festibúnað.



OSTRZEŻENIE

Nieprawidłowy montaż

Spadnięcie produktu może skutkować ciężkimi obrażeniami.

- ▶ Przed montażem sprawdzić nośność ściany.
- ▶ Przed montażem sprawdzić, czy dołączone elementy mocujące są odpowiednie do danego typu ściany. W razie potrzeby wymienić elementy mocujące.



FIGYELMEZTETÉS

Szakszerűtlen szerelés

A termék leesése súlyos sérüléseket okozhat.

- ▶ Szerelés előtt ellenőrizze a fal teherbíró képességét.
- ▶ Szerelés előtt ellenőrizze, hogy a mellékelt rögzítési anyag megfelelő-e a faltípushoz. Szükség esetén cserélje ki a rögzítési anyagot.



VAROVANIE

Neodborná montáž

Spadnutie výrobku môže viesť k ťažkým zraneniam.

- ▶ Pred montážou skontrolujte nosnosť steny.
- ▶ Pred montážou skontrolujte, či dodaný prípevňovací materiál je vhodný pre príslušný typ skrine. V prípade potreby vymeňte prípevňovací materiál.



VÝSTRAHA

Nesprávná montáž

Pád výrobku může způsobit vážné úrazy.

- ▶ Před montáží zkontrolujte nosnost zdi.
- ▶ Před montáží zkontrolujte, zda je použitý upevňovací materiál vhodný pro daný typ zdi. V případě potřeby použijte jiný upevňovací materiál.



OPOZORILO

Nestrokovna montaža

Posledica padca izdelka so lahko težke poškodbe.

- ▶ Pred montažo preverite nosilnost stene.
- ▶ Pred montažo preverite, ali je dobavljeni pritrdilni material primeren za tip stene. Pritrdilni material po potrebi zamenjajte.



UPOZORENJE

Nestručna montaža

Pad proizvoda može uzrokovati teške ozljede.

- ▶ Prije montaže provjerite nosivost zida.
- ▶ Prije montaže provjerite je li isporučeni pričvrtni materijal prikladan za tip zida. Po potrebi zamijenite pričvrtni materijal.



UPOZORENJE

Nestručna montaža

Padanje proizvoda može da dovede do teških povreda.

- ▶ Pre montaže ispitati nosivost zida.
- ▶ Pre montaže ispitati da li je isporučeni materijal za pričvršćenje pogodan za vrstu zida. Po potrebi, zameniti materijal za pričvršćenje.



HOIATUS

Asjatundmatu montaaž

Toote allakukkumine võib põhjustada raskeid vigastusi.

- ▶ Kontrollige enne montaaži seina kande võimet.
- ▶ Kontrollige enne montaaži, kas kaasa-solev kinnitusmaterjal sobib seinatüübi jaoks. Vajaduse korral vahetage kinnitusmaterjal välja.



BRĪDINĀJUMS

Nelietpratīga montāža

Produkta nokrišana var izraisīt smagas traumas.

- ▶ Pirms montāžas pārbaudiet sienas nestspēju.
- ▶ Pirms montāžas pārbaudiet, vai piegādes komplektā iekļautais stiprinājuma materiāls ir piemērots sienas tipam. Stiprinājuma materiālu nepieciešamības gadījumā nomainiet.



ĮSPĖJIMAS

Netinkamas montavimas

Produkto nukritimas gali sukelti sunkių sužalojimų.

- ▶ Prieš montuodami patikrinkite sienos patvarumą.
- ▶ Prieš montuodami patikrinkite, ar kartu pateikta tvirtinimo priemonė tinka tokiam sienos tipui. Prireikus tvirtinimo priemonę pakeiskite.



ПРЕДУПРЕЖДЕНИЕ

Неправилен монтаж

Падането на продукта може да доведе до тежки наранявания.

- ▶ Преди монтажа проверете товароносимостта на стената.
- ▶ Преди монтажа проверете дали доставените материали за закрепване са подходящи за типа стена. При нужда подменете материалите за закрепване.



AVERTIZARE

Instalare necorespunzătoare

Căderea produsului poate cauza leziuni grave.

- ▶ Înainte de instalare, verificați capacitatea portantă a peretelui.
- ▶ Înainte de instalare, verificați dacă materialul de fixare livrat este adecvat pentru tipul de perete. Dacă este necesar, schimbați materialul de fixare.



ΠΡΟΕΙΔΟΠΟΙΗΣΗ

Λανθασμένη εγκατάσταση

Η πτώση του προϊόντος μπορεί να επιφέρει σοβαρούς τραυματισμούς.

- ▶ Πριν από την εγκατάσταση ελέγξτε τη φέρουσα ικανότητα του τοίχου.
- ▶ Πριν από την εγκατάσταση ελέγξτε αν το συνοδευτικό υλικό στερέωσης είναι κατάλληλο για τον τύπο του τοίχου. Εφόσον απαιτείται, αντικαταστήστε το υλικό στερέωσης.



UYARI

Hatalı Montaj

Ürünün düşürülmesi ciddi yaralanmalara yol açabilir.

- ▶ Montaj öncesinde duvarın taşıma kapasitesini kontrol ediniz.
- ▶ Montaj öncesinde birlikte verilen sabitleme materyalinin duvar tipi için uygun olup olmadığını kontrol ediniz. Gerekliyse sabitleme materyalini değiştiriniz.



ПРЕДУПРЕЖДЕНИЕ

Неквалифицированный монтаж

Падение изделия может привести к тяжелым травмам.

- ▶ Перед монтажом проверить несущую способность стены.
- ▶ Перед монтажом проверить, подходит ли входящий в комплект поставки крепежный материал для типа стены. При необходимости заменить крепежный материал.



警告

不恰当的安装

产品掉落可能会导致严重伤害。

- ▶ 安装前检查墙壁的承载能力。
- ▶ 安装前检查附带的固定材料是否适合墙壁类型。必要时更换固定材料。

تحذير

التركيب غير السليم

قد يؤدي سقوط المنتج إلى حدوث إصابات خطيرة.

- ◀ قبل التركيب قم بفحص قدرة تحمل الحائط.
- ◀ قبل التركيب، تحقق مما إذا كانت مادة التثبيت الموردة مع المنتج مناسبة لنوع الحائط. قم باستبدال مادة التثبيت عند الحاجة.



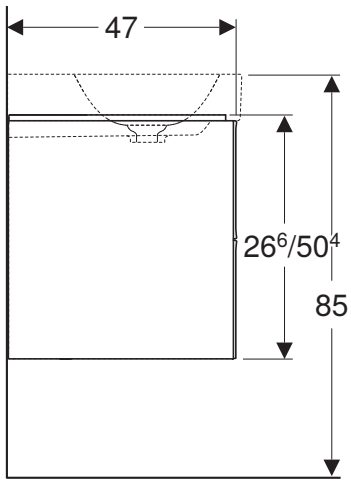

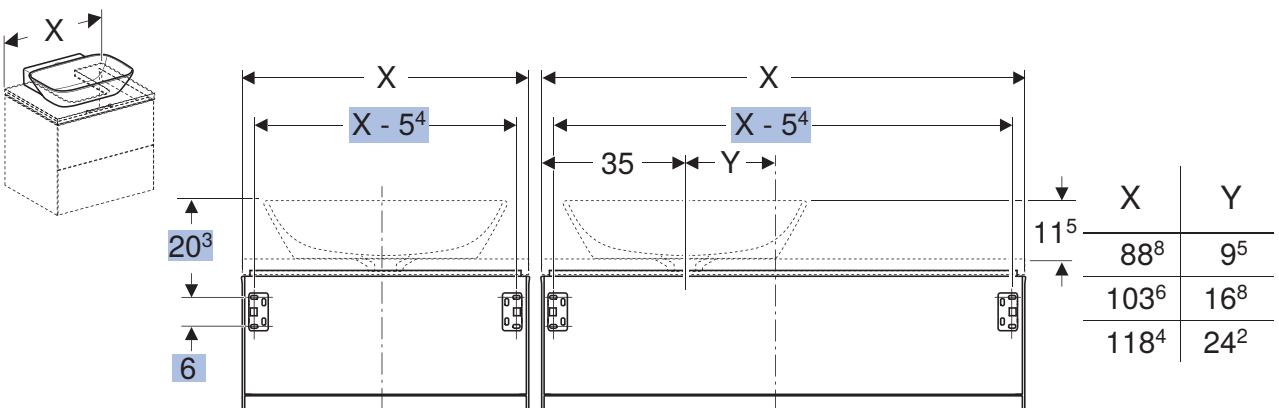
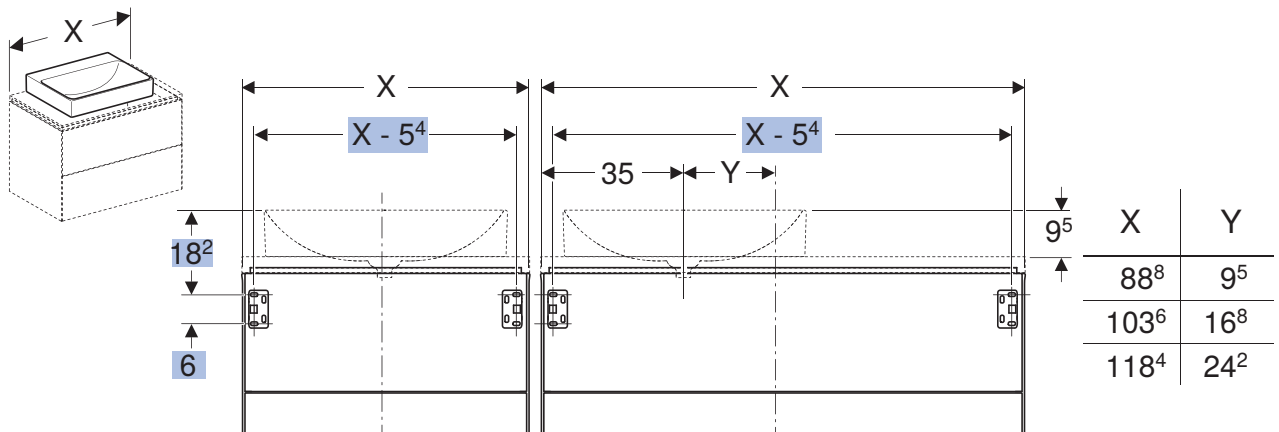
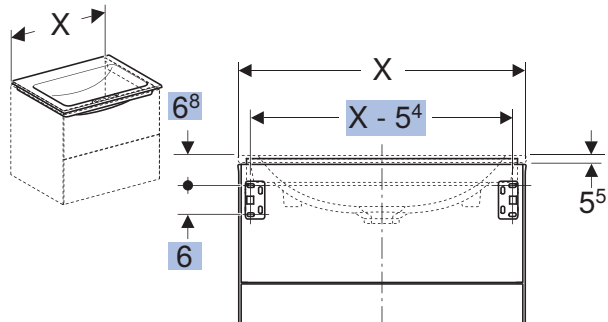
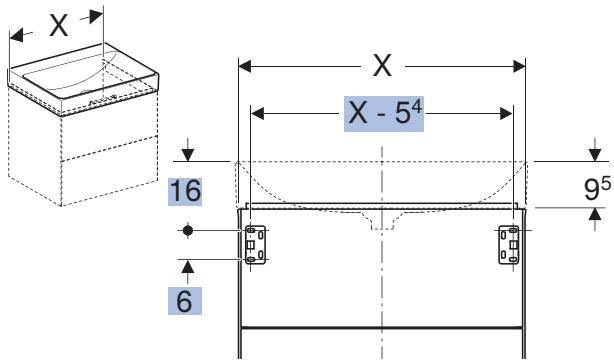

i

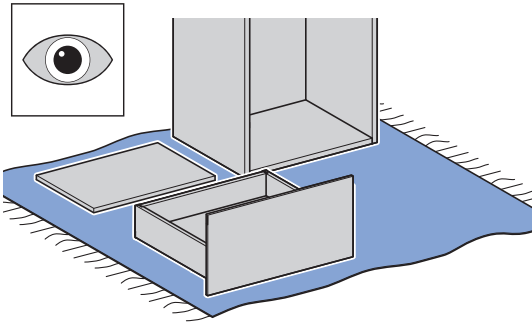

1

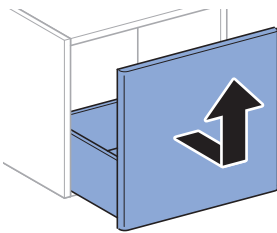

2

1

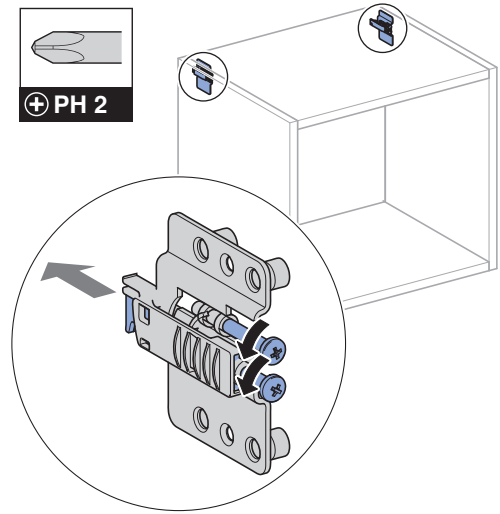
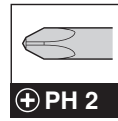

2

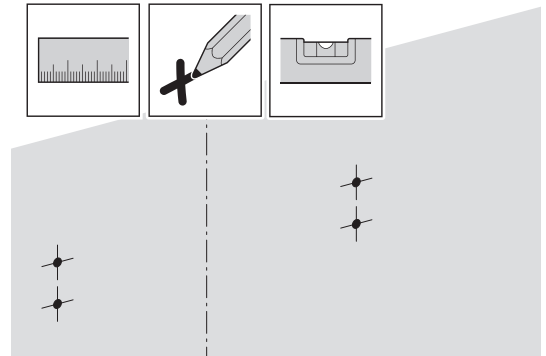
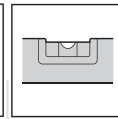
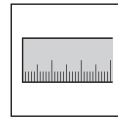
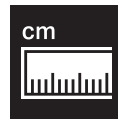
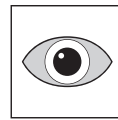

3

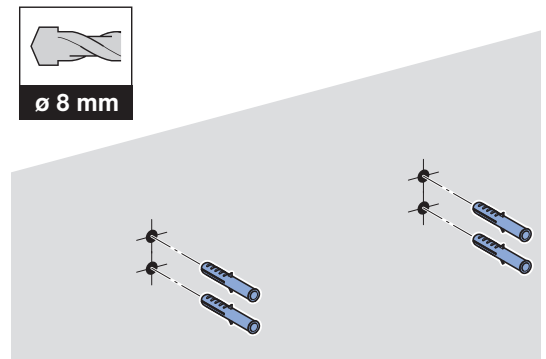
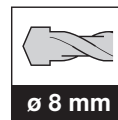

4

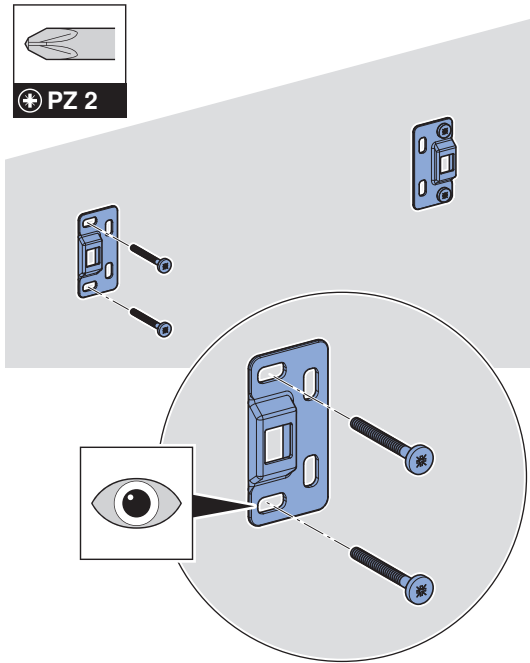

6

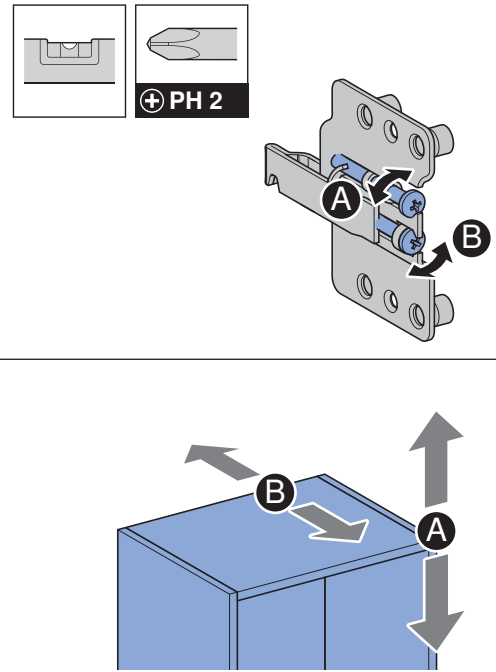

5

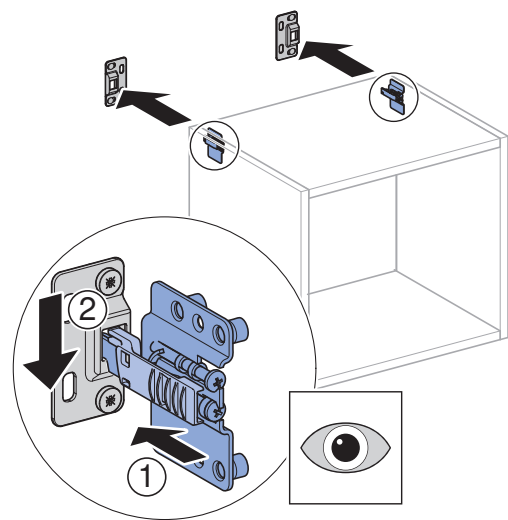

7

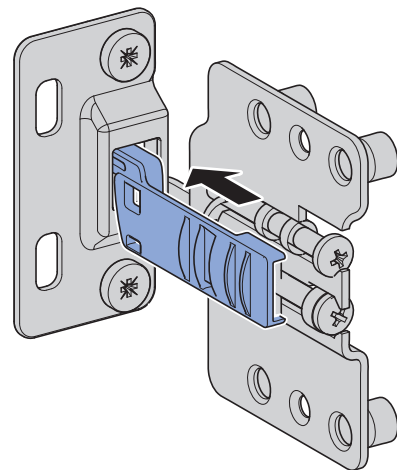

3

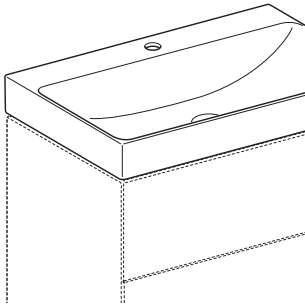
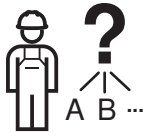

→ **3 A** 10

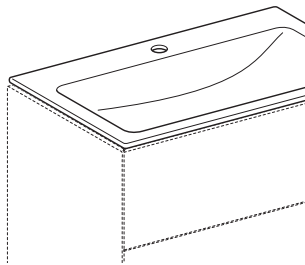

→ **3 B** 11

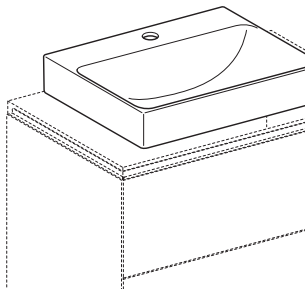

→ **3 C** 13

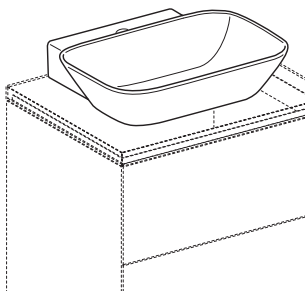

→ **3 D** 15

3 A

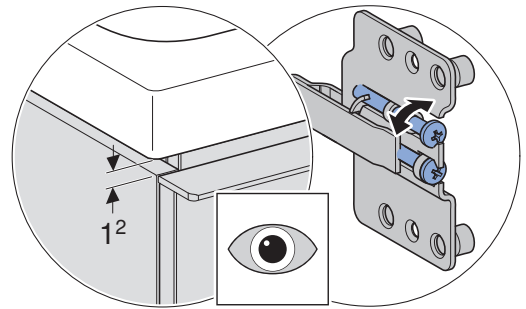
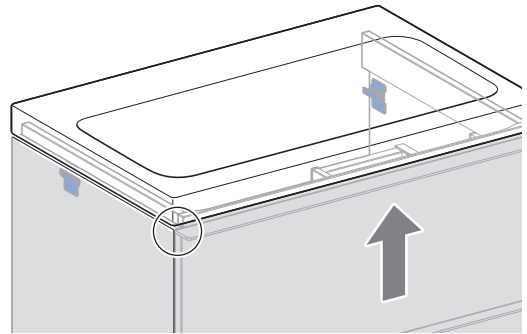

→ **4** 18

3 B

1

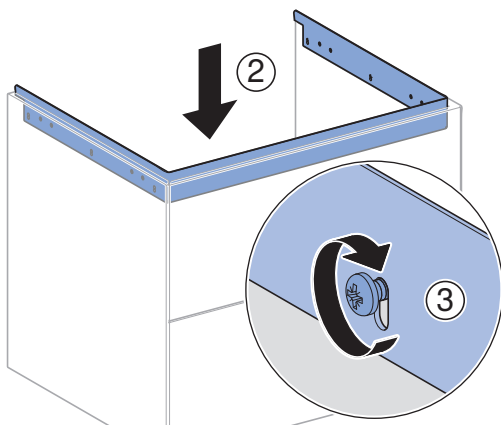
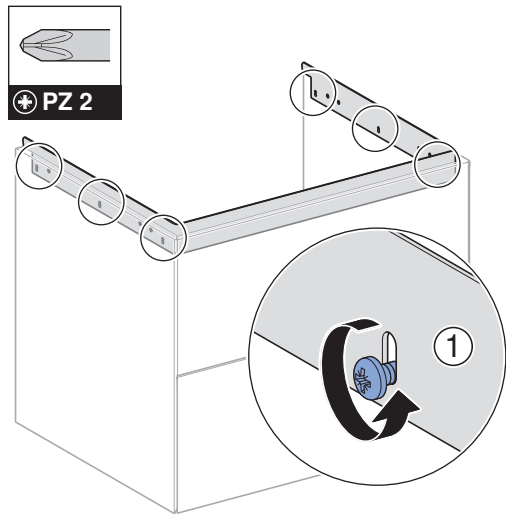

2

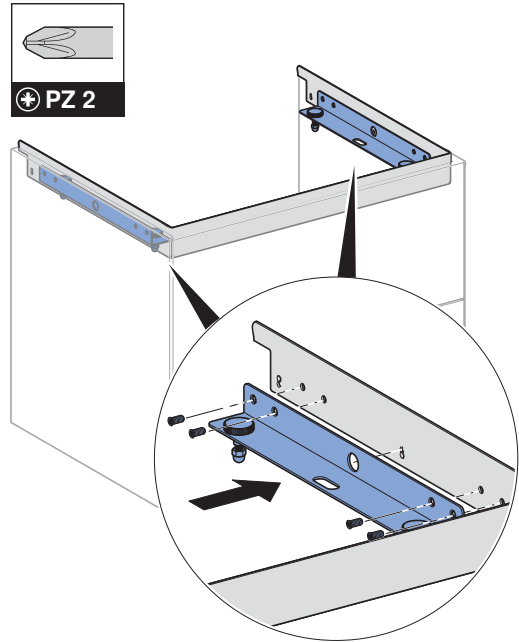
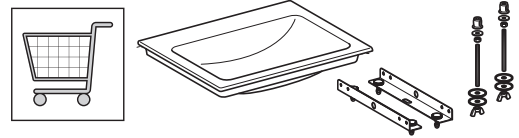

3

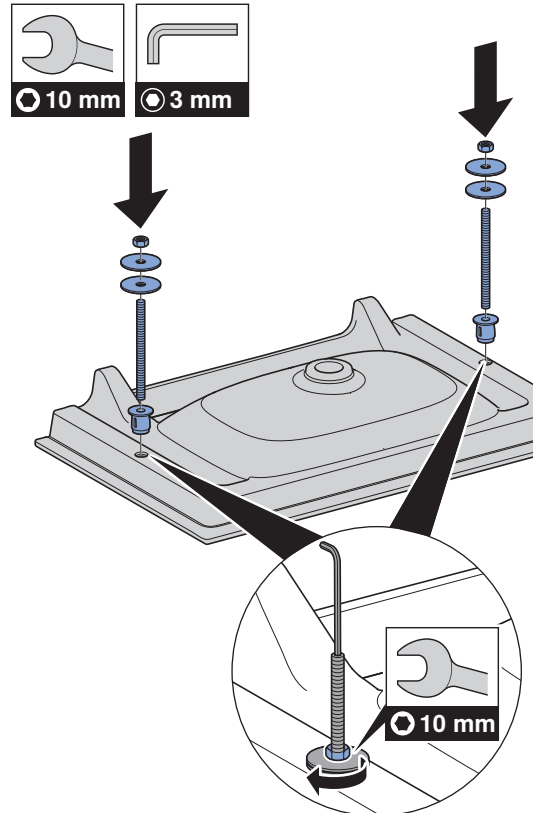

4

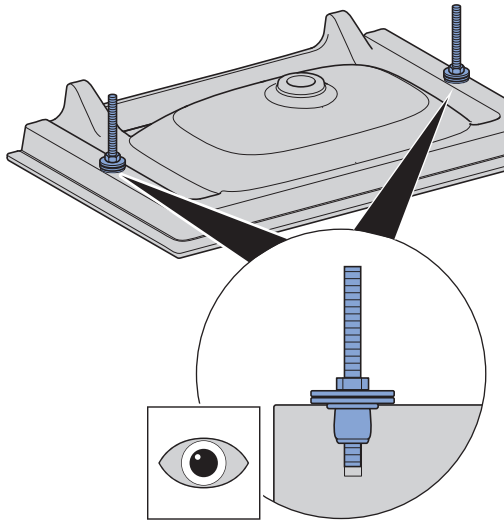

5

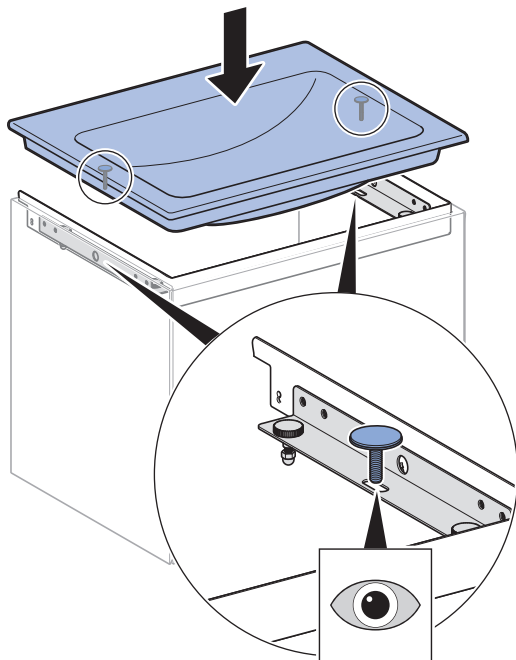

6

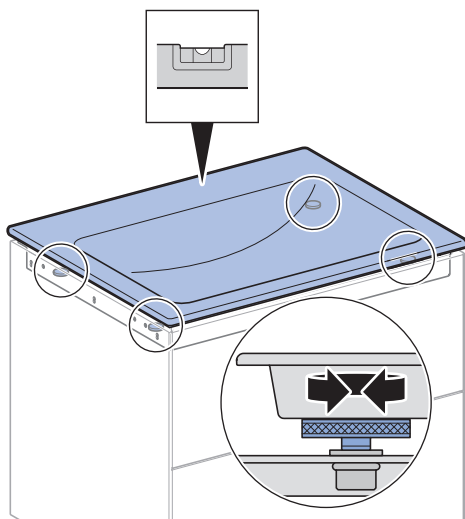

7

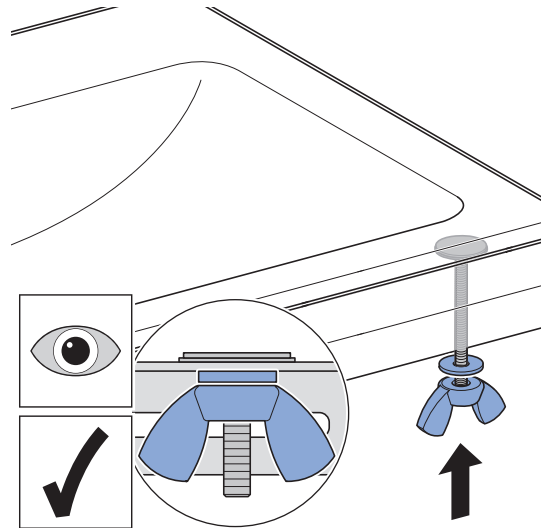

8

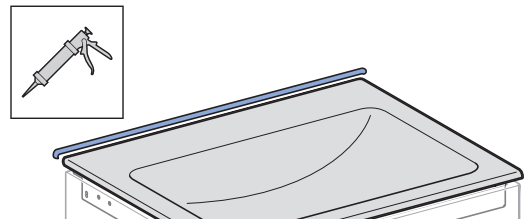

→ 4 18

3 C

1

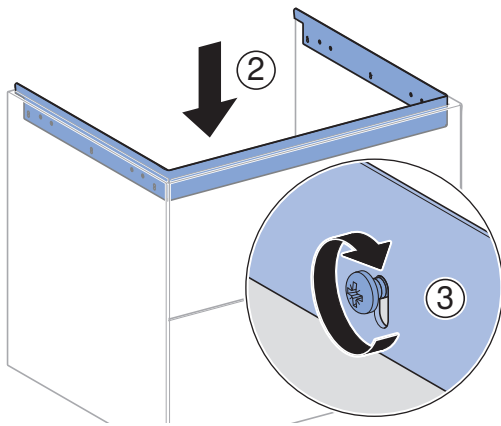
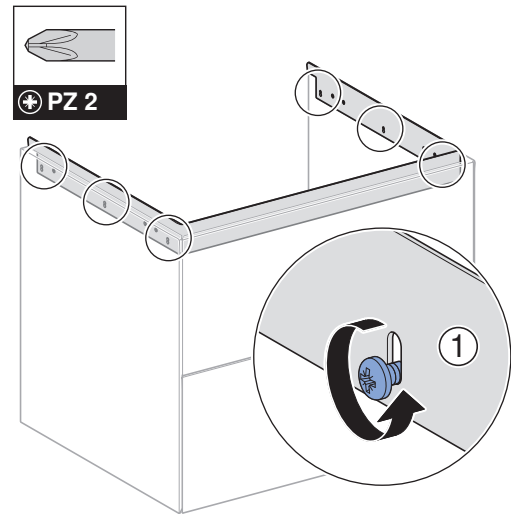

2

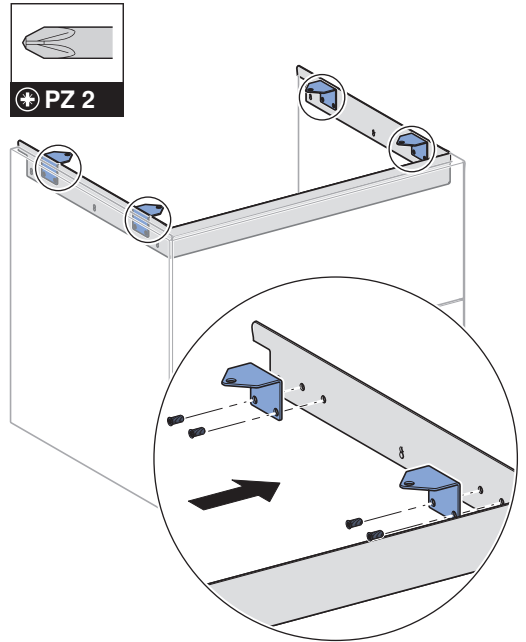
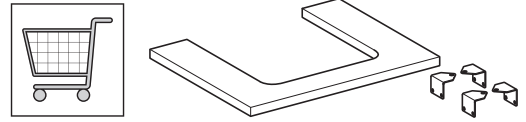

3

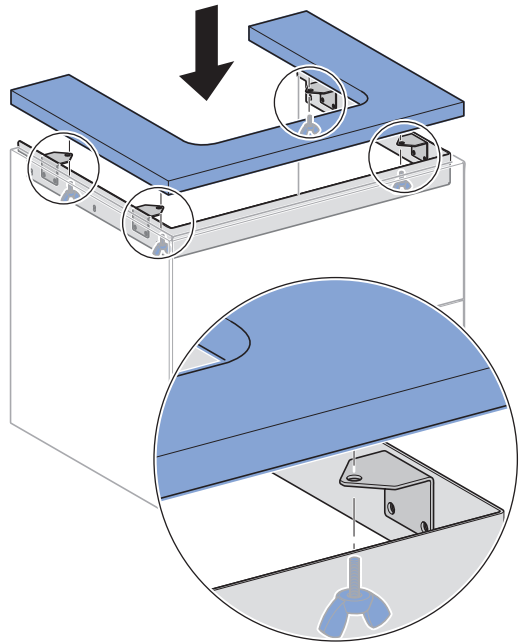

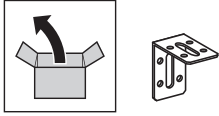

1 x / 2 x / 4 x

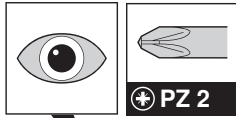

⊕ PZ 2

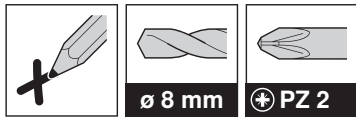
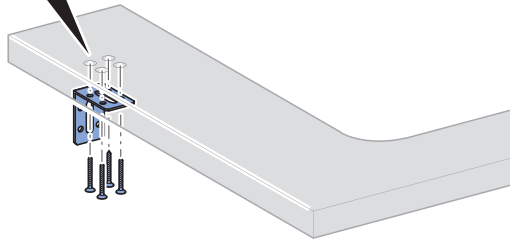

ø 8 mm

⊕ PZ 2

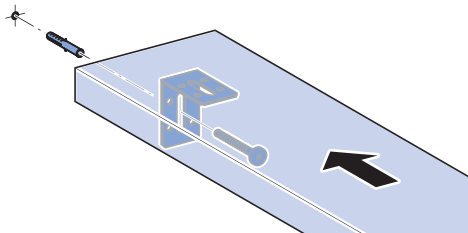

4

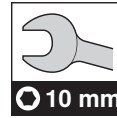
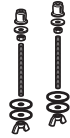
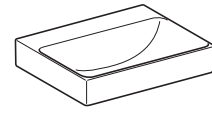

⊙ 10 mm

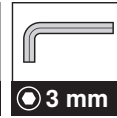

⊙ 3 mm

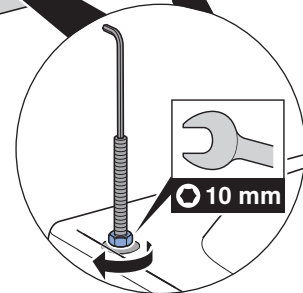
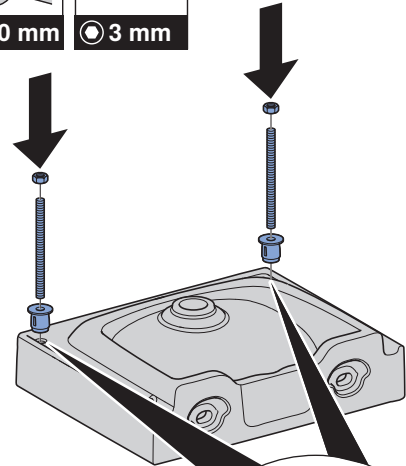

5

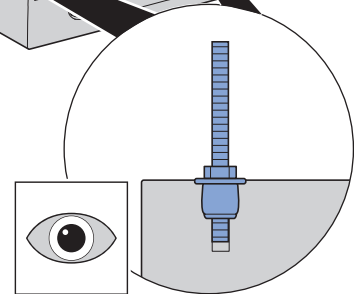
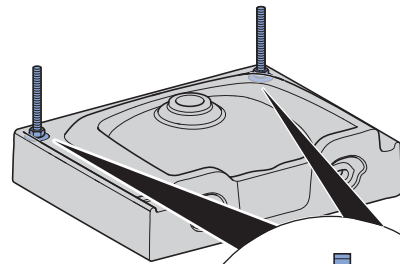

6

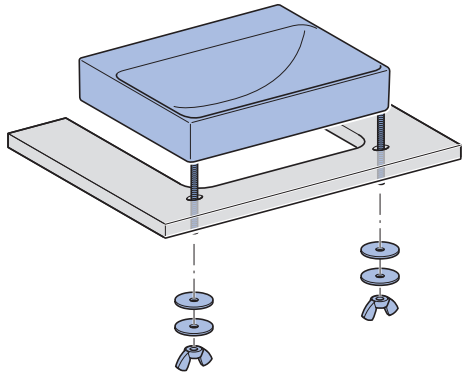

7

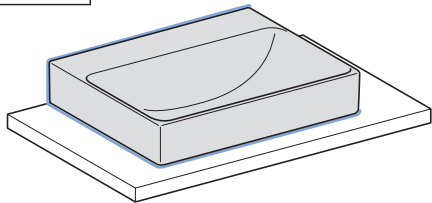

→ 4 18

3

D

1

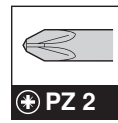

⊕ PZ 2

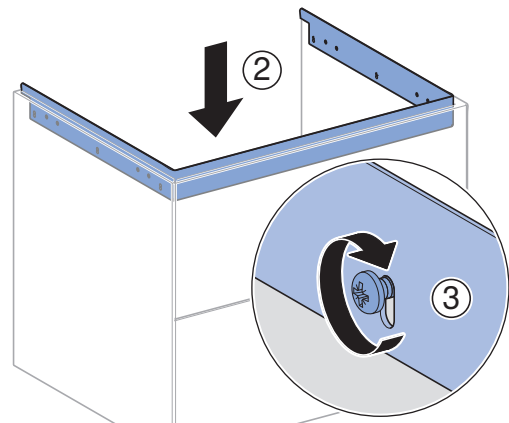
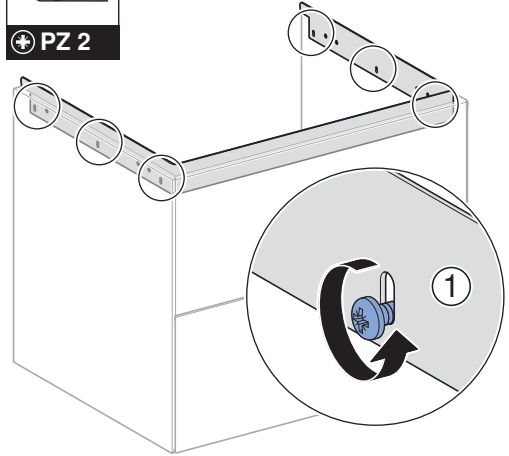

2

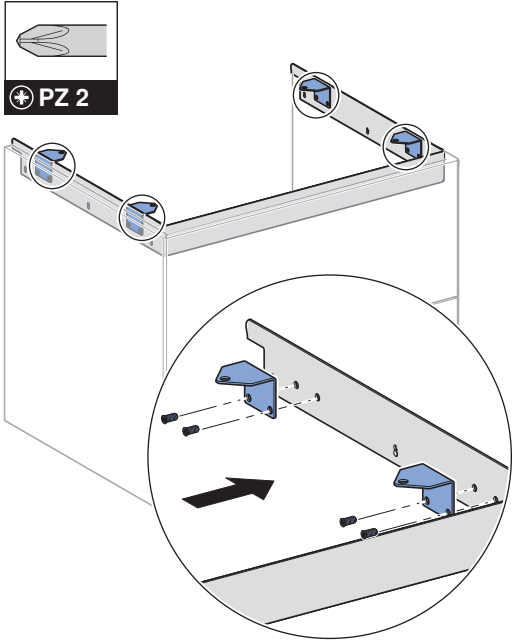
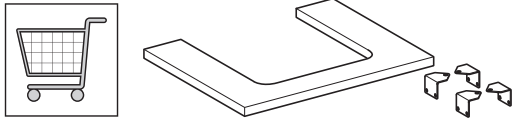

3

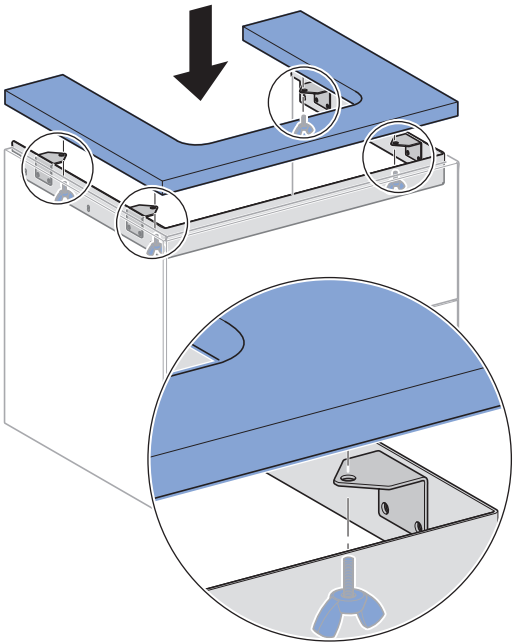

i

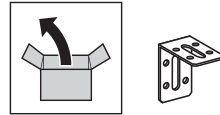

1 x / 2 x / 4 x

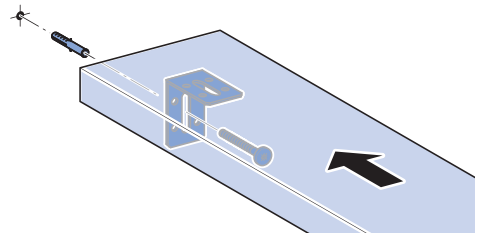
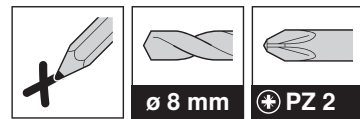
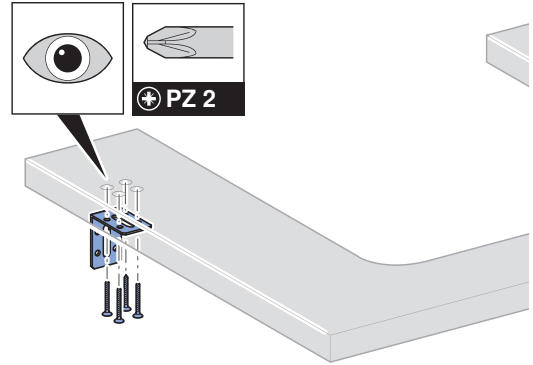

4

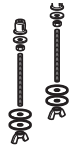

10 mm

3 mm

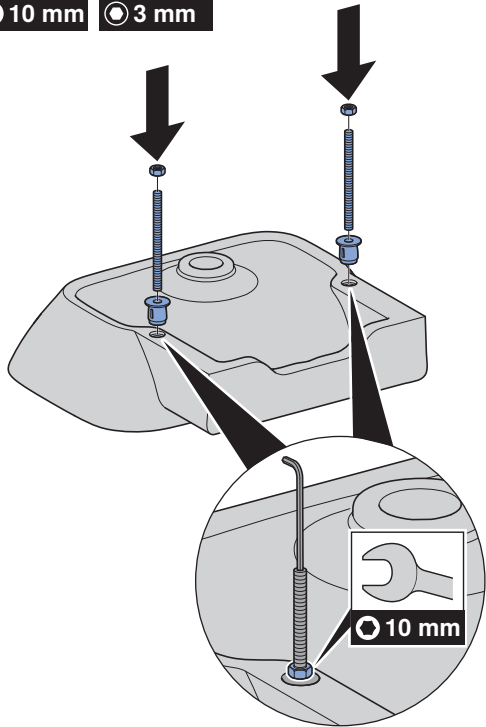

→ 4 18

5

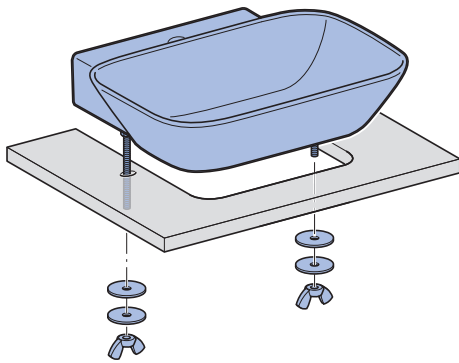

6

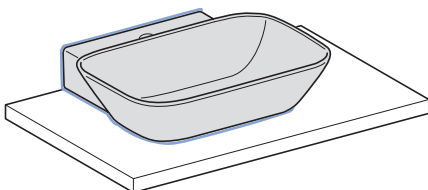

4

1

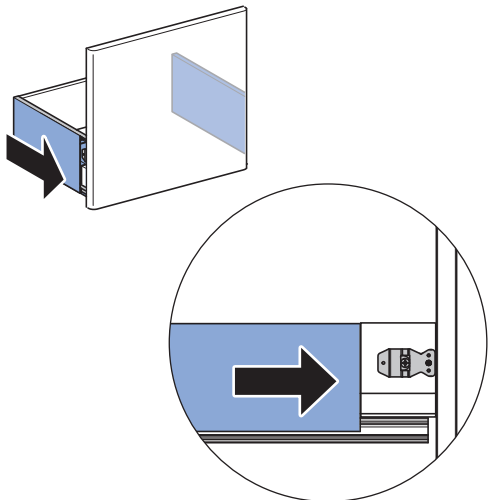
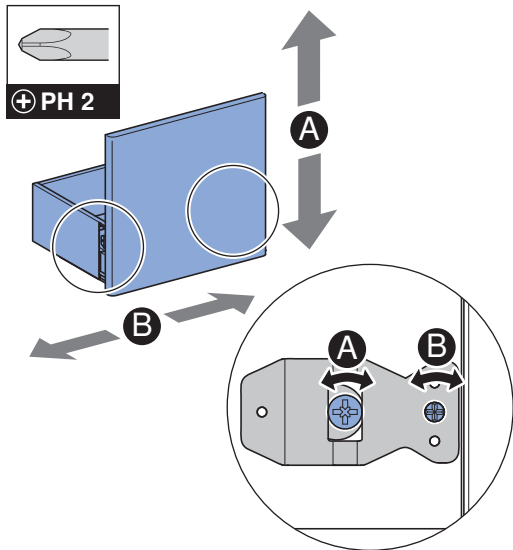
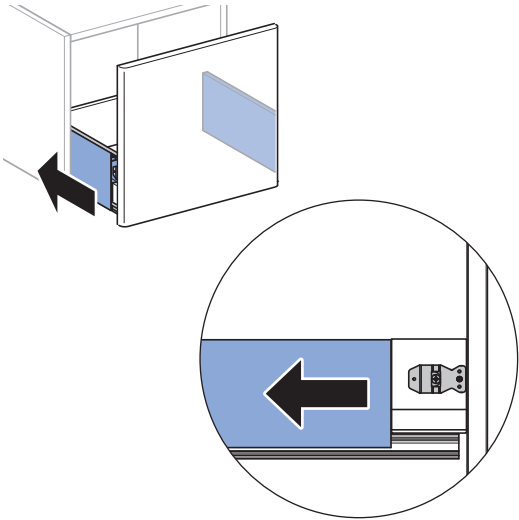

2

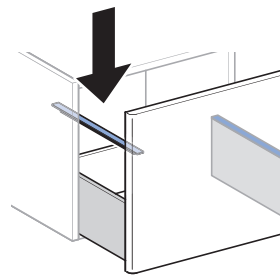
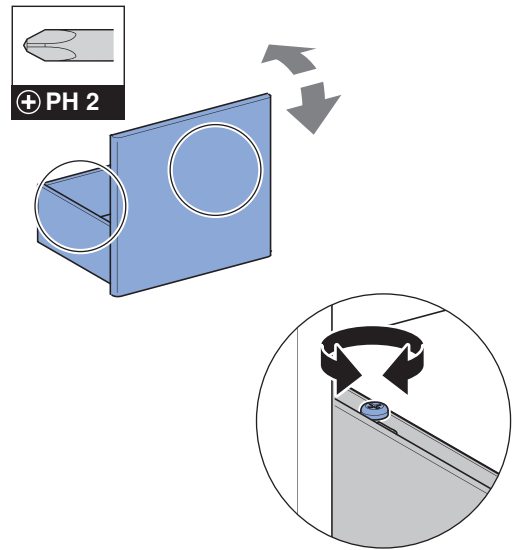
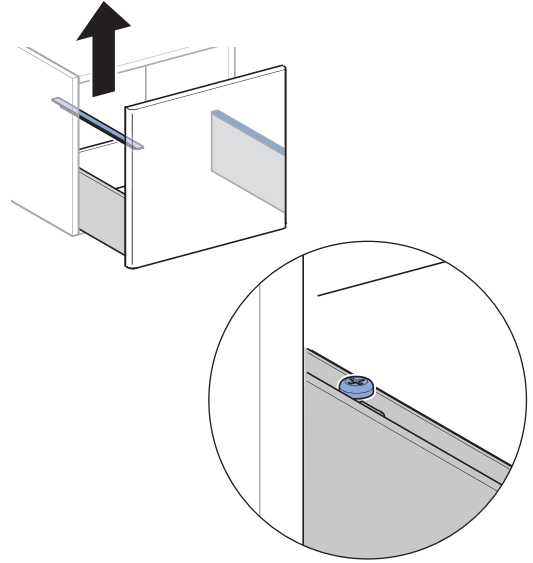



Geberit International AG
Schachenstrasse 77, CH-8645 Jona
documentation@geberit.com
www.geberit.com